

**GlacialTech®**  
*Enlighten Your Humanity*

2014



## Eco-Friendly Solution Provider

GlacialTech is committed to playing the role of an eco-friendly solution provider and stands steadfastly to "Green Promise" to keep away from harmful manufacturing processes that jeopardize our precious environment.



## Overview

GlacialTech Inc., established in June 2001, is a diversified provider of cooling, power supply and PC enclosure solutions for consumers and industrial applications. Its technological areas of expertise include specialized thermodynamic theory, mounting and soldering technologies, mechanism design, test and verification environment buildup as well as advanced thermal conduction material development.

Having established strong relationships with LED semiconductor suppliers as well as thermal, SMPS and mechanism technology leaders worldwide, GlacialTech leverages world-class engineers, efficient manufacturing capabilities and finest-quality materials to provide its high brightness, high efficacy LED lighting products for indoor, outdoor and other customized applications with an optimal balance between performance and cost.



## Company Profile

### Headquarter :

GlacialTech Inc.  
9F, No. 352, Sec. 2 Zhongshan Rd. Zhonghe Dist., New Taipei City, Taiwan,  
23557

.....

**Established :** 2001

.....

**Capital :** US\$ 3.2 Million

.....

**Quality Certified :** ISO 14001 & ISO 9001

.....

### Subsidiary Company :

GlaicalTech (China)  
深圳市福田区皇岗路高科利花园大厦高雅阁9C

.....

### Major Production Lines :

LED lighting products  
LED driver / Open frame / Battery charger  
Cooling solutions for PC, consumer and industrial equipments

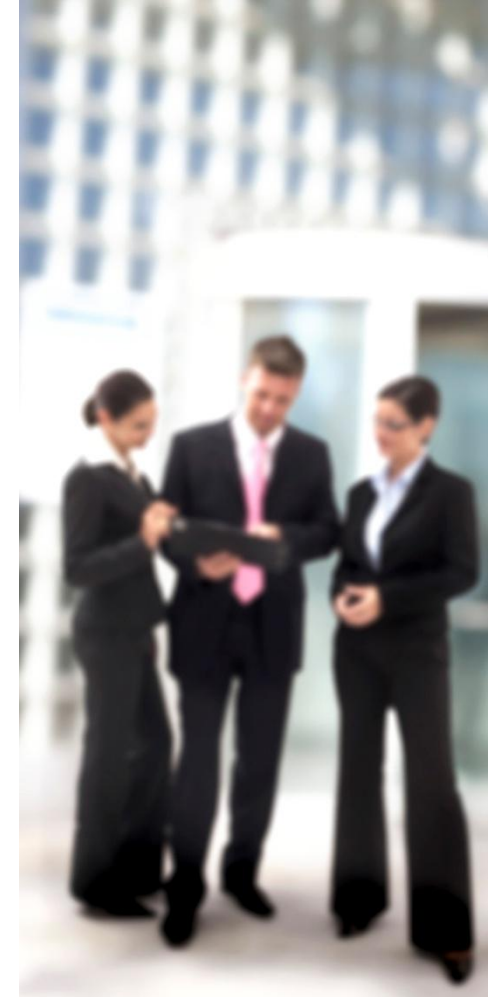

## Missions

---

### Specialty

GlacialFamily always does its level best to assure all of its customers of the highest quality, reliability & customers' satisfaction.

### Quality

Provides advanced technology and excellent material consultants as well as shares successful experiences with customers.

### Responsibility

Customer first, high added value service orientation.

### Environment Protection

GlacialFamily is committed to be an eco-friendly solution provider and keeps away from harmful manufacturing processes that jeopardize our precious environment.

### Efficiency

To raise company's core competitiveness, all the staffs do their level best all the time to upgrade the quality and velocity of research & development.



# Core Competitiveness

## Eco-Friendly Solution Provider

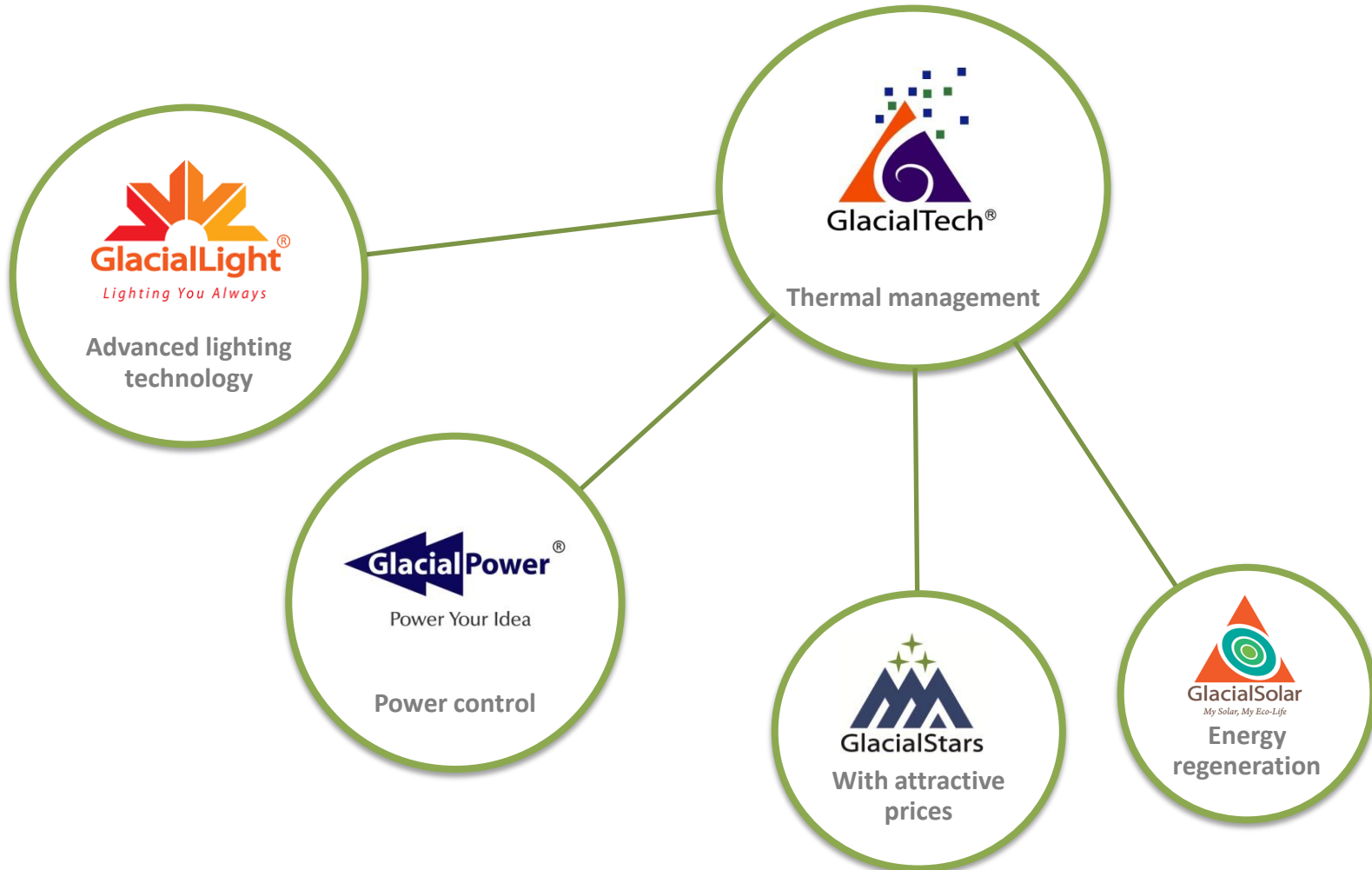

## Production Lines Snapshots

Production lines are furnished with automatic testing equipments strictly monitoring product quality and reliability to bring peace of mind to customers.



## Optical Instruments

Efficient measurement of light source near-field color and luminance distributions for optical design and simulation.



Benefit: The measurement is performed from within the near-field of the light source, enabling a compact measurement setup and facilitating optical analysis and design.



## Integrating Sphere Measurement System

GlacialTech has a 0.3m and a 1.5m integrating sphere. The 0.3m integrating sphere is mainly used to confirm the due qualities of LED chips and the 1.5m integrating sphere is mainly used to verify the due properties of LED lighting products designed.





## GP Test Instruments



CHROMA model 8000 SMPS auto test system (right)  
Giant force temperature & humidity chamber (left)



TEKTRONIX TDS 5034B Digital Phosphor Oscilloscope



CHROMA model 6530 programmable AC source



TEKTRONIX TDS 7054 Digital Phosphor Oscilloscope



CHROMA 6314 DC Electronic Load



CHROMA model 6630 Power Analyzer (up)

# Certificates

## ISO 9001

**CERTIFICATE** 

**Management system as per  
ISO 9001 : 2008**

In accordance with TÜV NORD CERT procedures, it is hereby certified that

**GLACIALTECH INC.**  
9F, No. 352 & 6F, No. 346, Sec.2, Jung Shan Rd.,  
Jung He City, Taipei, Taiwan, R.O.C.

applies a management system in line with the above standard for the following scope

**Design and Production Management of Coolers, Thermal  
Modules, Chassis, Switching Mode Power Supply and LED  
Lighting Products**

Certificate Registration No. 44 100 102168      Valid until 2013-06-02  
Audit Report No. 2.5-3688/2010      Initial Certification 2010-06-03

  
Certification Body  
at TÜV NORD CERT GmbH      Hong Kong, 2010-06-03

This certification was conducted in accordance with the TÜV NORD CERT auditing and certification procedures and is  
subject to regular surveillance audits.

TÜV NORD CERT GmbH    Langemarkstrasse 20    45141 Essen    www.tuev-nord-cert.com

  
TÜV NORD CERT GmbH

ROC: FE3986, CA 0190, 9172.8

## ISO 14001

**CERTIFICATE** 

**Management system as per  
ISO 14001 : 2004**

In accordance with TÜV NORD CERT procedures, it is hereby certified that

**GLACIALTECH INC.**  
9F, No. 352 & 6F, No. 346, Sec.2, Jung Shan Rd.,  
Jung He City, Taipei, Taiwan, R.O.C.

applies a management system in line with the above standard for the following scope

**Design and Production Management of Coolers, Thermal  
Modules, Chassis, Switching Mode Power Supply and LED  
Lighting Products**

Certificate Registration No. 44 104 102173      Valid until 2013-06-03  
Audit Report No. 2.5-3688/2010      Initial Certification 2010-06-04

  
Certification Body  
at TÜV NORD CERT GmbH      Hong Kong, 2010-06-04

This certification was conducted in accordance with the TÜV NORD CERT auditing and certification procedures and is  
subject to regular surveillance audits.

TÜV NORD CERT GmbH    Langemarkstrasse 20    45141 Essen    www.tuev-nord-cert.com

  
TÜV NORD CERT GmbH

ROC: FE3986, CA 0190, 9172.8



# GL Certificates

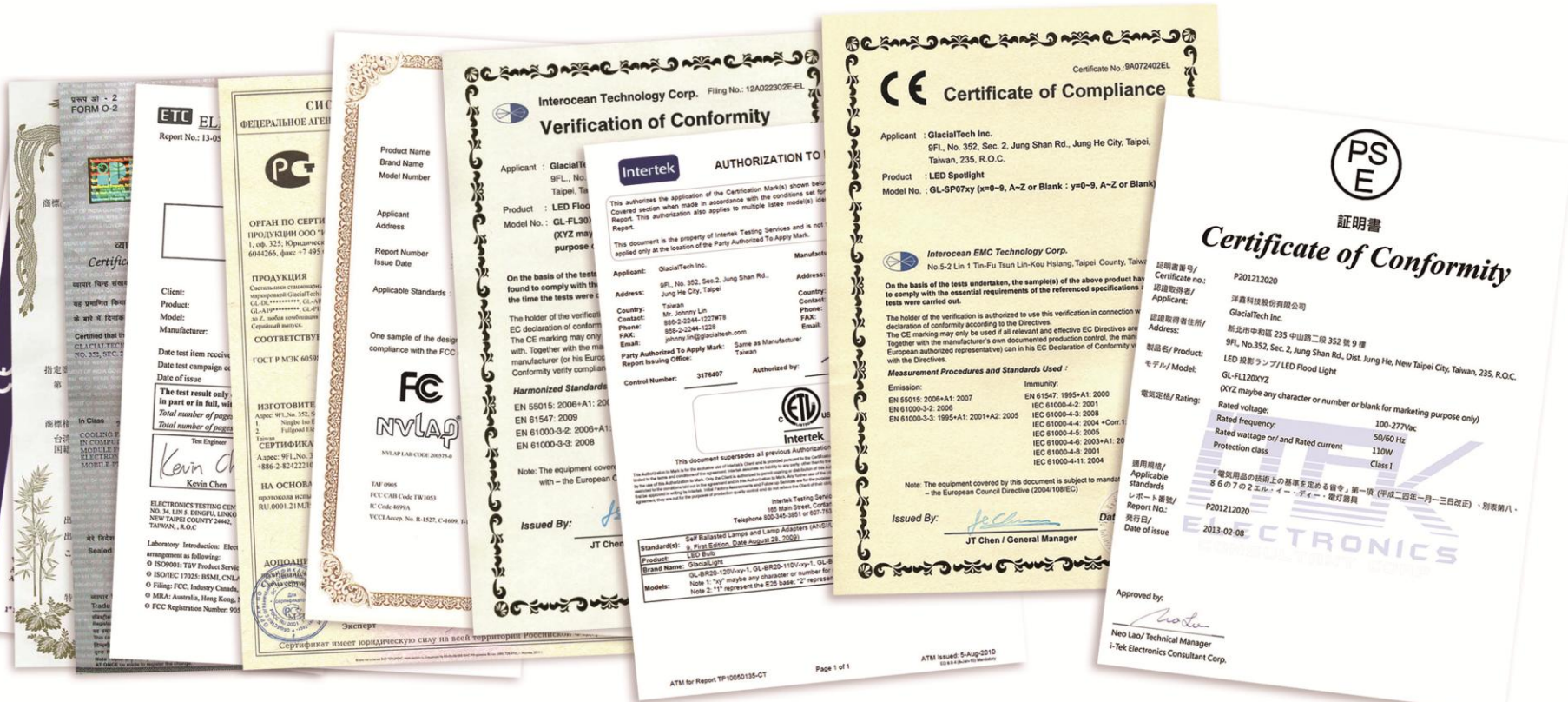

## GP Certificates

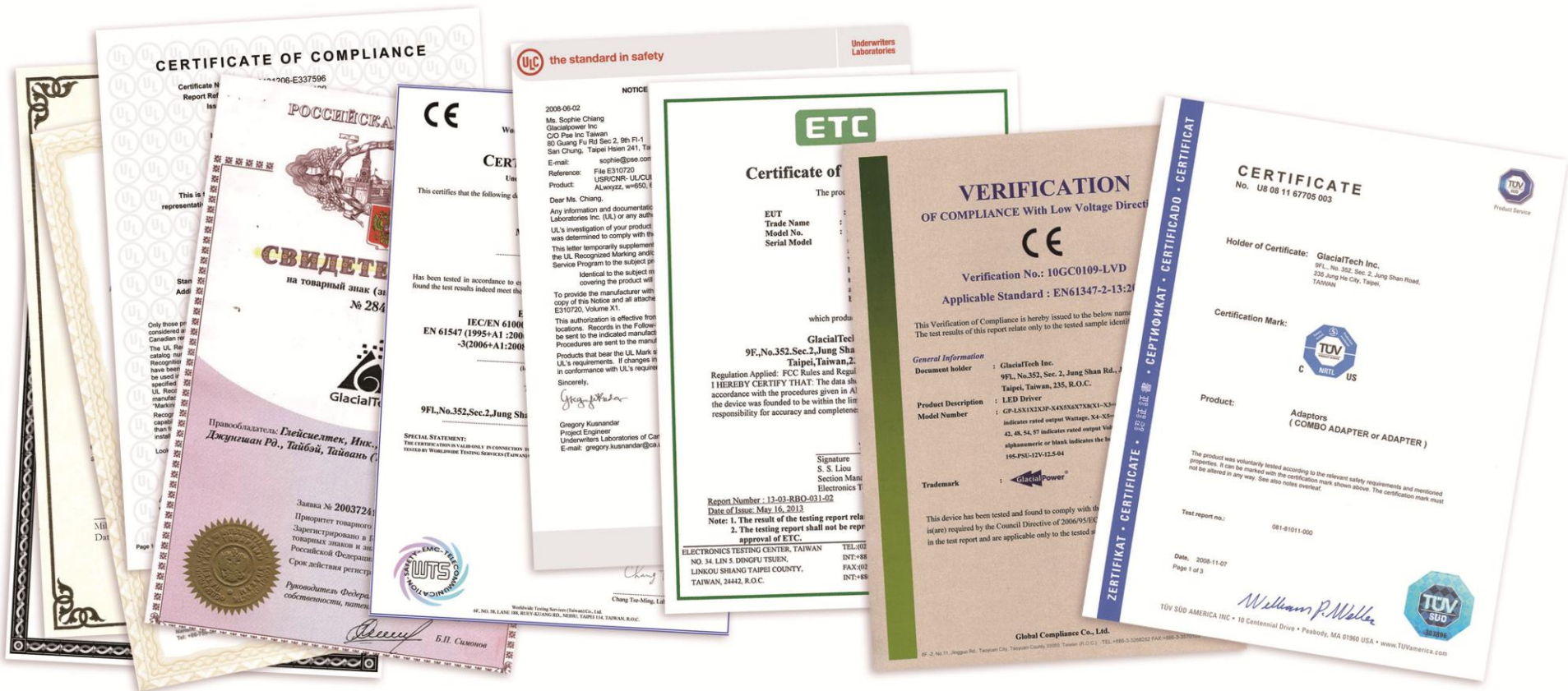



# Achievements

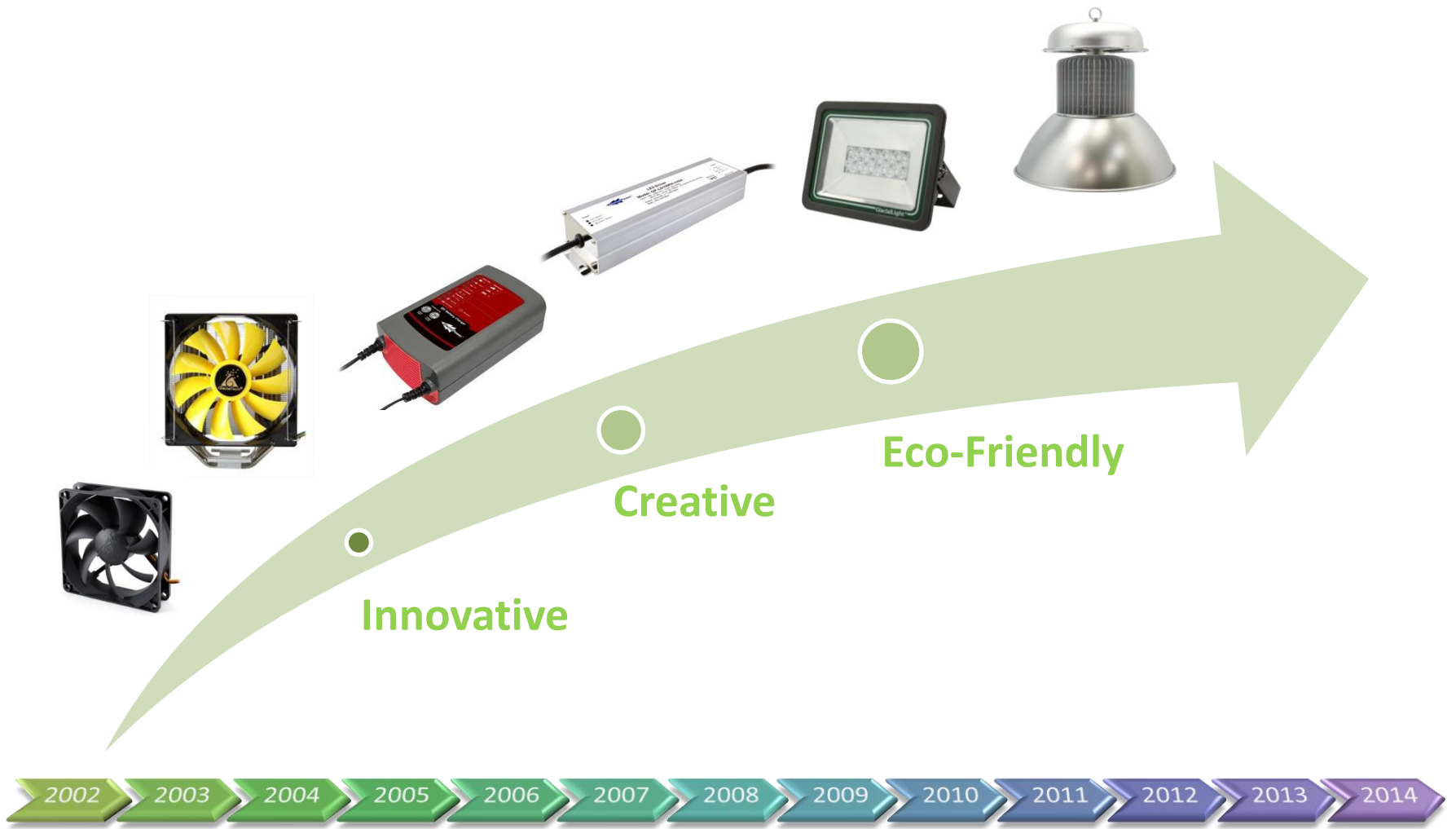

## Innovation & Diversification Objectives

All GlacialFamily products comply with governmental safety and EMI regulations.



**High Efficiency:**  
Enhancing efficiency to reduce power .

**High Reliability:**  
Increasing reliability & lifetime to reduce material waste.

**Super Silence:**  
Striving for ultimate silence to provide users with noise-free environments.





9 F, No. 352, Sec. 2, Zhongshan Rd., Zhonghe Dist., New Taipei City, Taiwan, 235, R.O.C.  
Tel: +886 2 2244-1227 Fax: +886 2 2244-1228



## Products & Solutions

### Desktop CPU Cooler

- Multi-platform Solutions
- Intel CPU Cooler
- AMD CPU Cooler



### Cooling Pad

- Igloo Pad Series
- M-Flit Series
- V- Shield Series
- SnowPad Series



## Products & Solutions

### DC Fan

- Fix Speed Fan
- PWM Fan



### Thermal Grease

- Ice Therm I
- Ice Therm II



### Server Cooler

- LGA 771
- LGA775
- LGA1156
- LGA1366

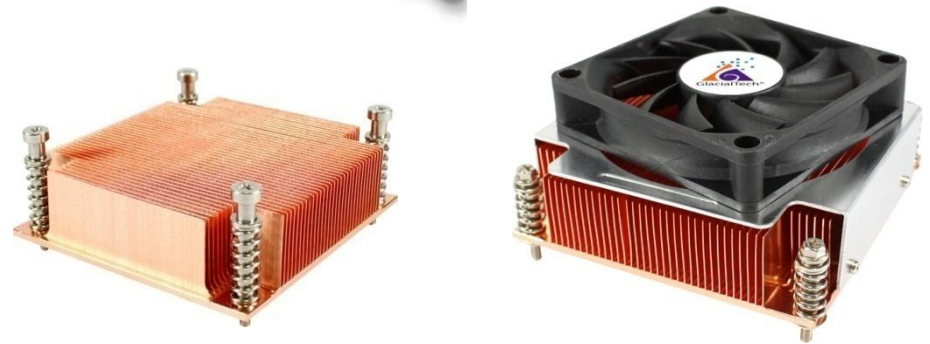

## Products & Solutions

### Tailor-made Solutions

- Soldering
- Extrusion
- Skived
- Stamping
- Die-Casting
- Thermal solution for all in one PC
- Thermal solution for laser
- Thermal solution for communication devices
- Stack Fin Module



### Chassis

- Chassis (Tailor-made Solution )
- LCDPC Chassis
- Chassis Solution of Terminal System





## Visited and Appreciated by President of the Russian Federation

The President of the Russian Federation, Dmitry Medvedev, who visited to one of the biggest Russian System Integrator's factory in Obninsk which produces personal computers, workstations, monoblock PCs, servers, storage systems, i-kiosks and other computer equipment, gave a high appraisal to the products where GlacialTech's cooling systems are used.

The latest monoblock systems – the first in Russia which combine a monitor and a powerful computational system, use low-profile combined coolers from GlacialTech with compact ribbed heatsinks and heatpipes. GlacialTech's coolers used in modern systems, effectively remove heat from the CPU and critical components delivering efficient and almost noiseless cooling.

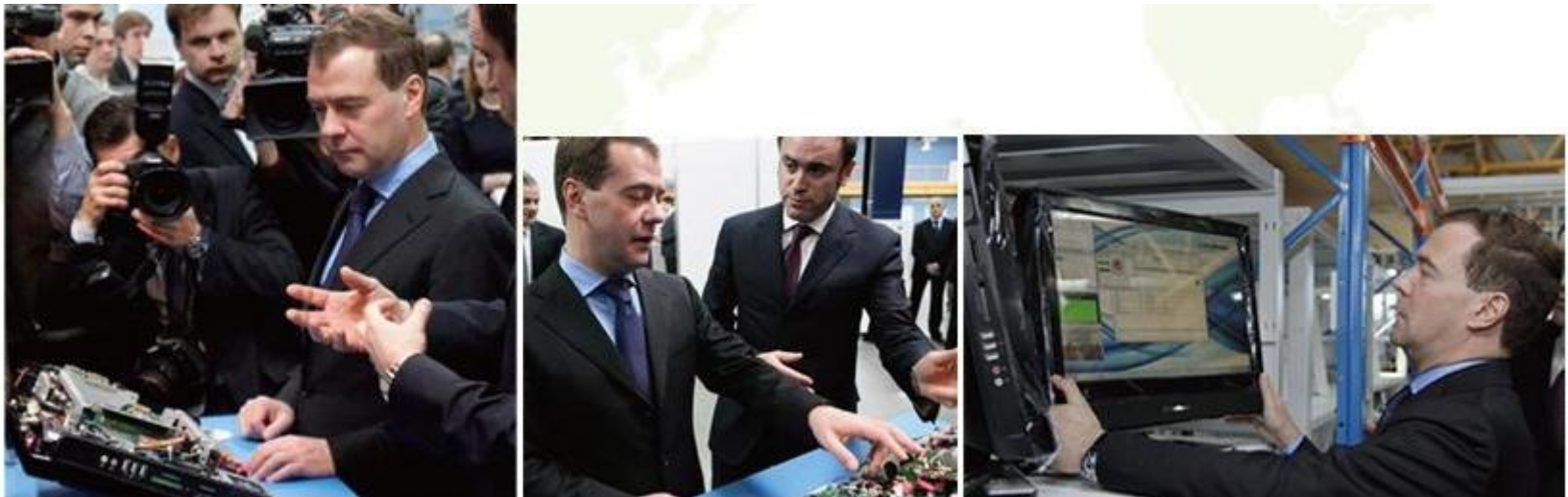



**GT Patents**





Power Your Idea



[www.GlacialPower.com](http://www.GlacialPower.com)



9 F, No. 352, Sec. 2, Zhongshan Rd., Zhonghe Dist., New Taipei City, Taiwan, 235, R.O.C.  
Tel: +886 2 2244-1227 Fax: +886 2 2244-1228

## Typical Products Lineup

### LED Driver Module

- **General Type**  
HS/LE Series  
LC /LV Series
- **Terminal Type**  
LC /LV Series
- **PFC Function** (Isolation cable)  
RS Series
- **PFC Function Type**  
HS/LS/LP Series  
LS50/70/100/150/200P Series
- **PFC + High Voltage Output**  
LS100PH/LS150PH Series
- **PFC + C.V mode dimming**  
LP60P Series
- **PFC + 4 Step dimming**  
LP60P Series

- **PFC + 3 in 1 dimming** (Isolation cable)  
RS Series
- **PFC + AC Dimming Type**  
TS/TL/TH Series
- **PFC + DC Dimming Type**  
LS/HS/LP Series
- **DC-DC LED Driver**  
LD Series
- **DALI Interface**  
GL-DA02 Series

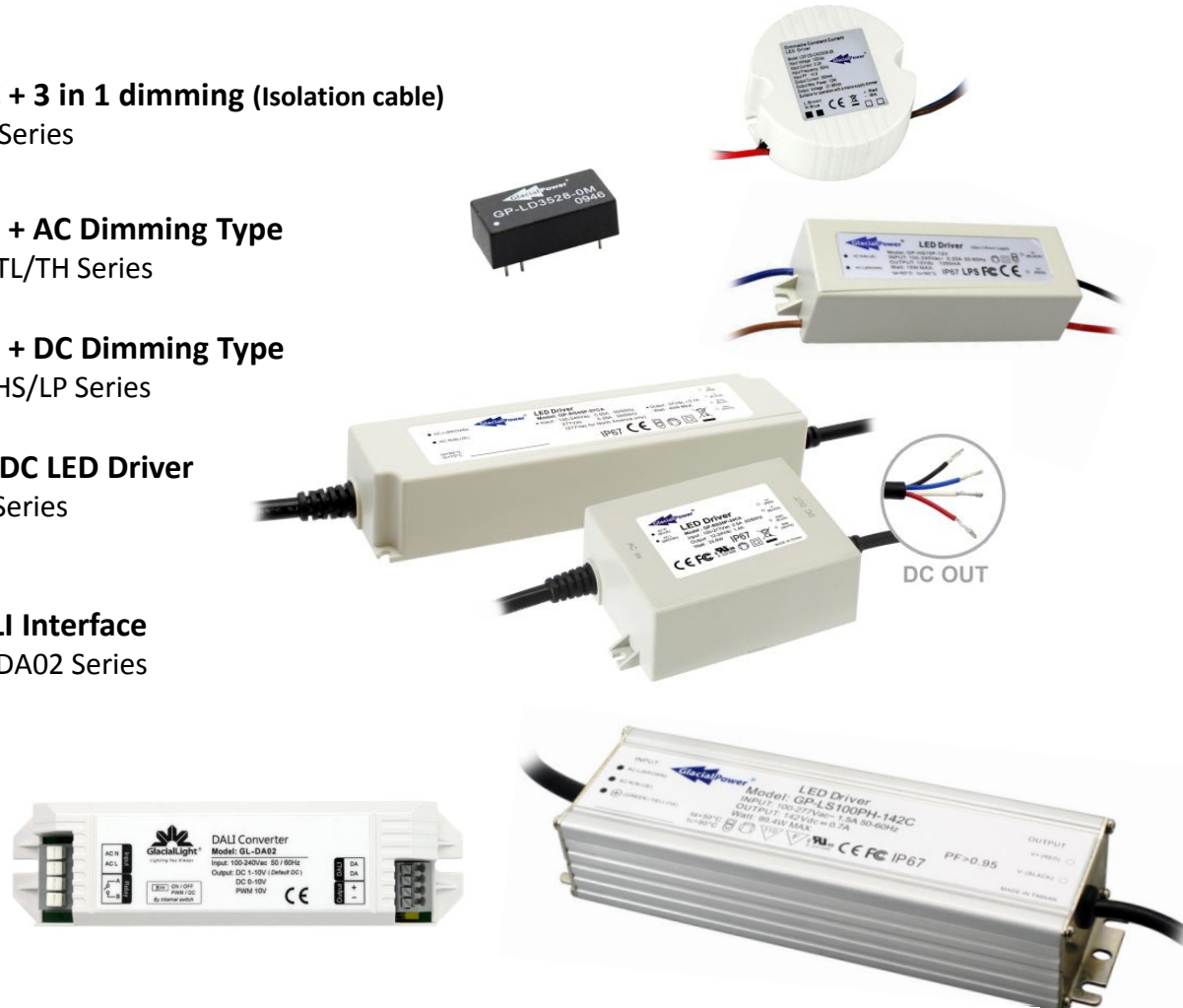



## Typical Products Lineup

### Battery Charger

#### ■ 12V Charger

FA1210 Series  
CZ1204 Series  
CZ1206 Series

#### ■ 24V Charger

FA2407G Series  
FA2407S Series  
CZ2404 Series



### Open Frame Power Supply

#### ■ Single Output

25 /45 /60 Watts AC-DC Single Output

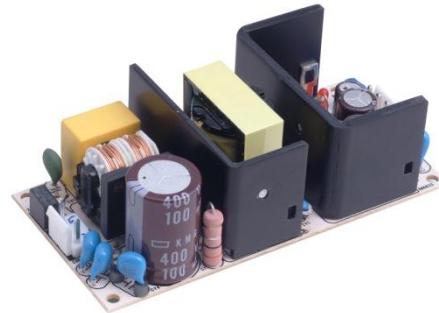



**GP Patents**





9 F, No. 352, Sec. 2, Zhongshan Rd., Zhonghe Dist., New Taipei City, Taiwan, 235, R.O.C.  
Tel: +886 2 2244-1227 Fax: +886 2 2244-1228

## GlacialLight Product Line

### Interior Lighting



- ◆ AR111-V2
- ◆ Bay Light
- ◆ Down Light
- ◆ Panel Light
- ◆ Troffer Light
- ◆ Track Light

### Exterior Lighting



- ◆ Flood Light
- ◆ Wall-mounted luminaires

### Lighting Control



- ◆ DALI Interface Converter

### SKD Solutions

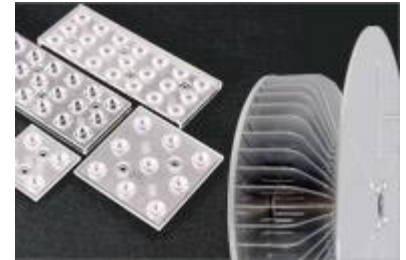

- ◆ Thermal Components
- ◆ Lighting Modules
- ◆ Lens
- ◆ Thermal Pastes



**GlacialLight Cares**

Lighting  
You Always

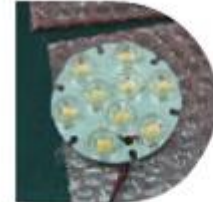

LED Board Assembly

LED Board Assembly  
(with Lens Cover)



Power Board Assembly

Shell Assembly

Burn in

High Voltage Leakage &  
Breakdown Test

Power Consumption  
& Power Factor Test



Fixed Socket Base

Led Cover Assembly

Barcode

Outlook Viewing Check

Barcode



## LED Lamps

### ■ Non-Dimmable

- GL-AR111-V2AN-9 Series
- GL-AR111-V2AN-12 Series
- GL-BR30 Series
- GL-BR40 Series



### ■ AC-TRIAC Dimmable

- GL-AR111-V2ADL-9 Series
- GL-AR111-V2ADH-9 Series
- GL-AR111-V2ADL-12 Series
- GL-AR111-V2ADH-12 Series
- GL-BR30D Series
- GL-BR40D Series



## LED Down Light

### ■ AC input: Non-Dimmable

GL-DL04 Series  
 GL-DL06 Series/ GL-DL06-SM Series  
 GL-DL08 Series/ GL-DL08-SM Series  
 GL-DL10 Series/ GL-DL10-SM Series  
 GL-DL06-IP Series  
 GL-DL08-IP Series

### ■ AC input: Dimming Solutions

(AC-TRIAC / 3 in 1 Dimmable)

GL-DL04D Series  
 GL-DL06D Series/ GL-DL06D-SM  
 GL-DL08D Series/ GL-DL08D-SM  
 GL-DL06D-IP Series  
 GL-DL08D-IP Series

### ■ DC input: Non-Dimmable

GL-DL04LD/GL-DL04LD-SM Series  
 GL-DL06LD/GL-DL06LD-SM Series  
 GL-DL08LD/ GL-DL08LD-SM Series  
 GL-DL06LD-IP Series  
 GL-DL08LD-IP Series



Recessed Series



Surface Mount (SM Series)



metal bar



cable

Pendant Series



IP Series (Waterproof IP54)

## LED Panel Light / LED Troffer Light

### ■ Non-Dimmable

- GL-PL0303 Series
- GL-PL0306 Series
- GL-PL0312 Series
- GL-PL0606 Series
- GL-TL0606 Series

### ■ DC-Dimmable (1-10V/ PWM/ Resistor)

- GL-PL0303DA Series
- GL-PL0312DA Series
- GL-PL0606AD Series



LED Troffer Light

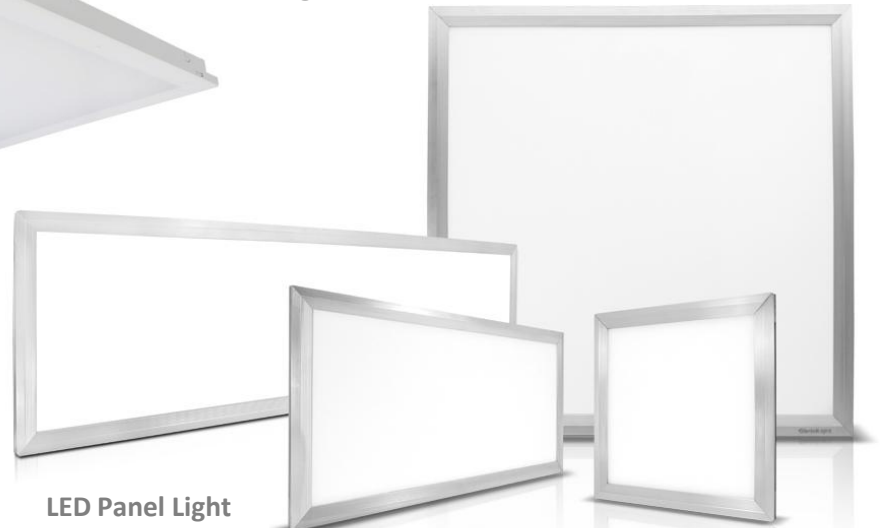

LED Panel Light

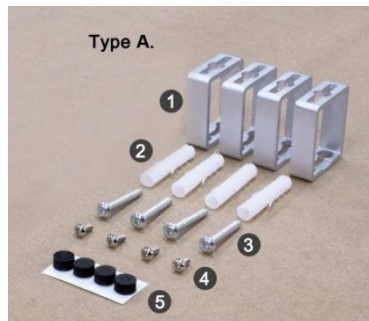

**PL Ceiling Accessories**  
For all Panel Light Products

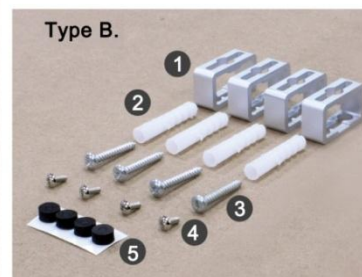

**Suspension Cables**  
For all Panel Light Products



**Suspension Cables**  
For Troffer Light Products

## LED Wall-mounted luminaires

GL-WL1012 Series  
GL-WL1012S Series



GL-WL1012



GL-WL1012S





## LED Flood Light

### ■ AC input

- GL-FL12 Series
- GL-FL30-V2 Series
- GL-FL60 Series
- GL-FL120 Series
- GL-FL180 Series

### ■ DC input

- GL-FD12 Series
- GL-FD30-V2 Series

### ■ PIR Sensor

- GL-FL12S Series
- GL-FL30S-V2 Series

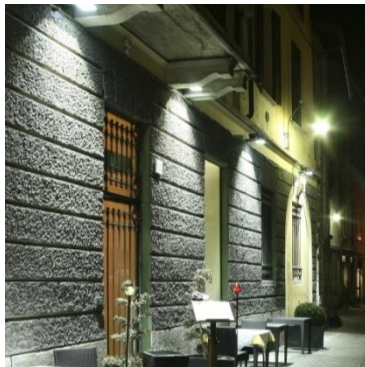

Can be integrated into solar application,  
directly connect to the battery without  
requiring a PV inverter.

## LED Bay Light

- GL-BL110 Series
- GL-BL220 Series



## SKD Solutions

- Thermal Components
- Lighting Modules
- Lens
- Thermal Pastes

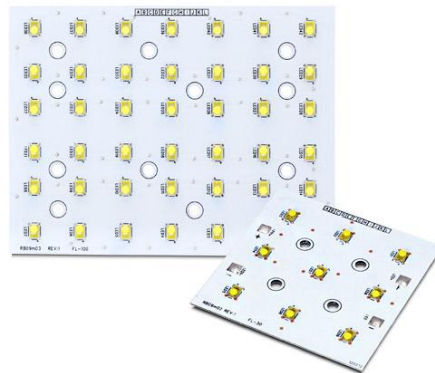



# Lighting Control

■ DALI Interface Converter

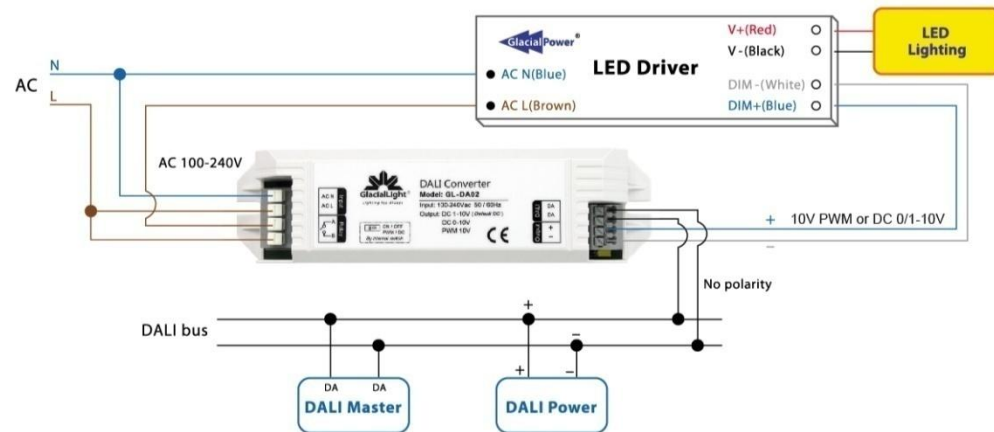

GL Patents





## 2014 New Product Line Planning

- ◆ **Emergency Lighting**
- ◆ **Explosion Proof Lighting Fixtures**

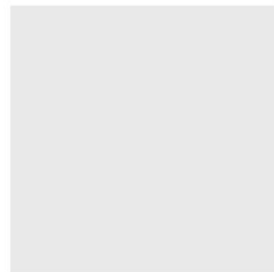
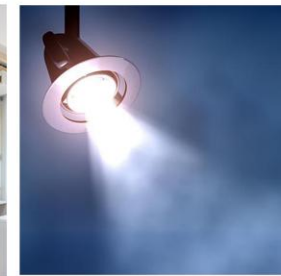
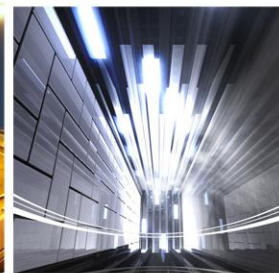



## Case Studies in Global Markets

- The largest Taiwan expressway service area (Dongshan) is redecorated with GlacialLight LED bay light, flood light, down light, AR111 and MR16(Tainan, Taiwan)



## Case Studies in Global Markets

- GlacialLight TL0606 troffer light installed at famous “Smart” supermarket chain stores located in Batumi city. (GEORGIA)



- GlacialLight bay light of GL-BL110 (WW) installed at famous trading network shop Kotryna in the PANORAMA shopping mall. (LITHUANIA)





## Case Studies in Global Markets

### ■ GlacialLight GL-BR30 installed at PORSCHE Showroom (Florida, USA)



### ■ GlacialLight GL-BR30 installed at Long Beach Convention Center (USA)





## Case Studies in Global Markets

- GL-SP30 Used for Solar PV Billboard (NORTH SUMATRA, Medan city, Setiabudi site)



- GL-SP15 used for Solar PV Power System (WEST JAVA, Puncak city, Setiabudi site)



- GL-SP30 Used for Solar PV Signboard (BANTEN, Tangerang city, Paramount Center site in INDONESIA)





## Case Studies in Global Markets

### ■ Heritage Awali Golf & Spa Resort with GlacialLight GL-SP07 (Domaine de Bel Ombre, Mauritius)



### ■ GlacialLight GL-FL120 LED flood light is used for billboard lighting at Suy Sing Commercial Corporation in Paranaque city (Philippines)





## Case Studies in Global Markets

- GlacialLight GL-DL04 are used for down light at whole building's windows (London)



- GlacialLight LED bay light of GL-BL110 are installed at supermarket in NY. (NY, USA)





## Case Studies in Global Markets

### ■ GlacialLight Flood Light installed at Spandau Arcaden Shopping Center (Germany)



### ■ GlacialLight Downlight installed at The Bank of BANCO POPULAR DOMINICANO (Dominican Republic)

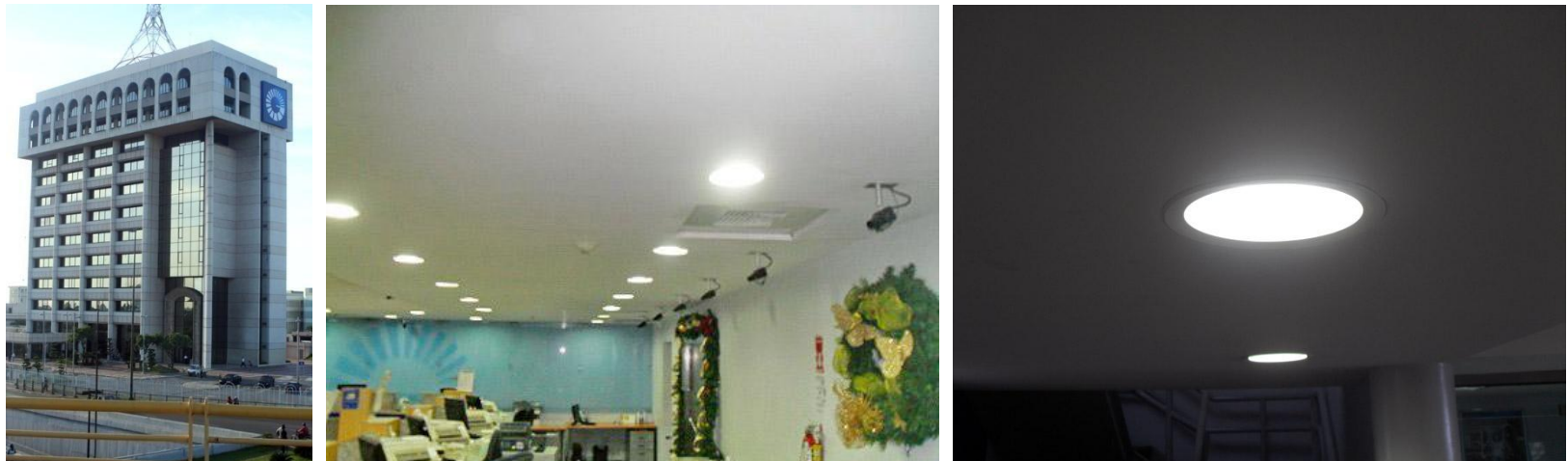



9 F, No. 352, Sec. 2, Zhongshan Rd., Zhonghe Dist., New Taipei City, Taiwan, 235, R.O.C.  
Tel: +886 2 2244-1227 Fax: +886 2 2244-1228

## Principle (Goal)

---

Our clients are located in all parts of the world. Irrespective of whether a business is small, medium or large or whether the business is a local, regional or global organization, we can meet their needs. GlacialTech specializes in end-to-end industry-specific solutions and specific know-how, which helps our clients increase their profitability by giving them a competitive edge.

The world these days feels smaller and smaller, and the pace of business is becoming extremely fast. This environment offers constant challenges to companies, some which are particularly fierce and can be difficult to overcome without strategic planning. Our constant strive for efficiency as well as willingness to collaborate, innovate, and think strategically in order to stay ahead of the curve makes us the ideal partner for your company in seeking to overcome present day challenges. To help you expand and meet your challenges is the way we reach our own success.



**Thanks for Your Attention**

